

TECHNICAL SPECIFICATIONS

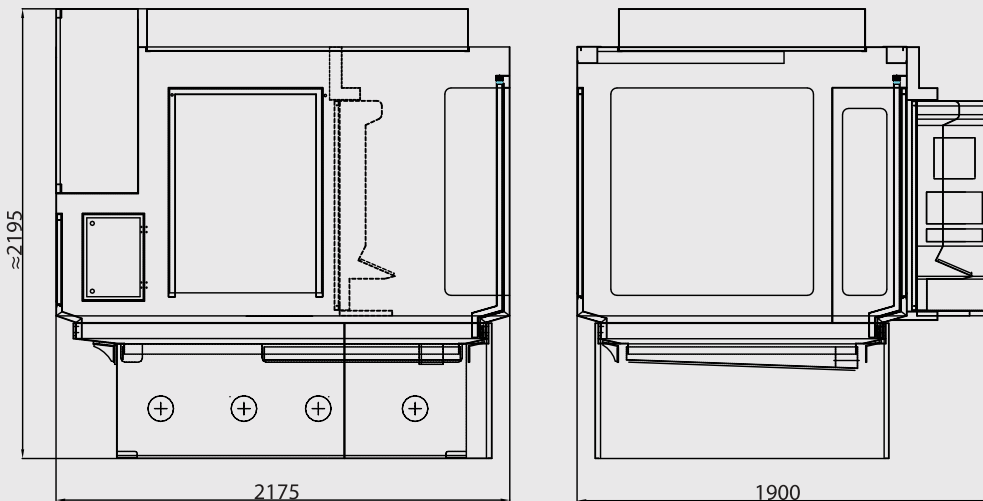

LINEAR AXES

Max.Stroke X-axis (longitudinal slide)	- 300 mm
Max.Stroke Y-axis (vertical slide)	- 260 mm
Max.Stroke Z-axis (cross slide)	- 265 mm
Maximum traverse speed	- 15 m/min
Control resolution	- 0.0001 mm

ROTARY AXES

Work Head Rotation A-axis	- 0-360°
Maximum Tool Swivel C-axis	-45° to 180°
Control resolution	- 0.0001°
Maximum traverse speed C-axis	- 10 rpm

MAXIMUM TOOL DIMENSIONS

Max.Tool dia. (Solid Carbide)	-32 mm (optimized range 2 to 20)
Max. Cutter Diameter	- 175 mm
Max. Peripheral grinding *	- 175 mm
Max.tool length for end grinding*	- 175 mm
Min. diameter of the tool	-2 mm #

WORK HEAD (A-axis)

Work spindle taper	- ISO 50
Centre height	- 155mm
Maximum rotation speed	- 40 rpm

OTHER DATA

Electrical Power	- 25kVA
Probing System	- Renishaw
Coolant System	- External
Approximate Weight	- 3200 Kgs.

* Distance from the ISO gauge plane

Schaublin collet system is recommended for manufacturing tools below 6 mm diameter.



For More Information about this machine, Please feel free to contact us.

Tool Grinding Technologies Inc.

Plot No. 467-469, 12th Cross, 4th Phase, Peenya Industrial Area, Bangalore - 560 058. INDIA
 Tel: 91(0) 80 4117 0352 Fax: 91 (0) 80 4117 9512 Mob: 91 98861 26239
 Email: sales@tgtindia.com Visit us: www.tgtindia.com